

Q1.(40 M.) For a simple low pass filter, when subjected to a step input, the voltage behavior across the capacitor (output) is given in the plot below, determine the numerical values for R, L, and C.

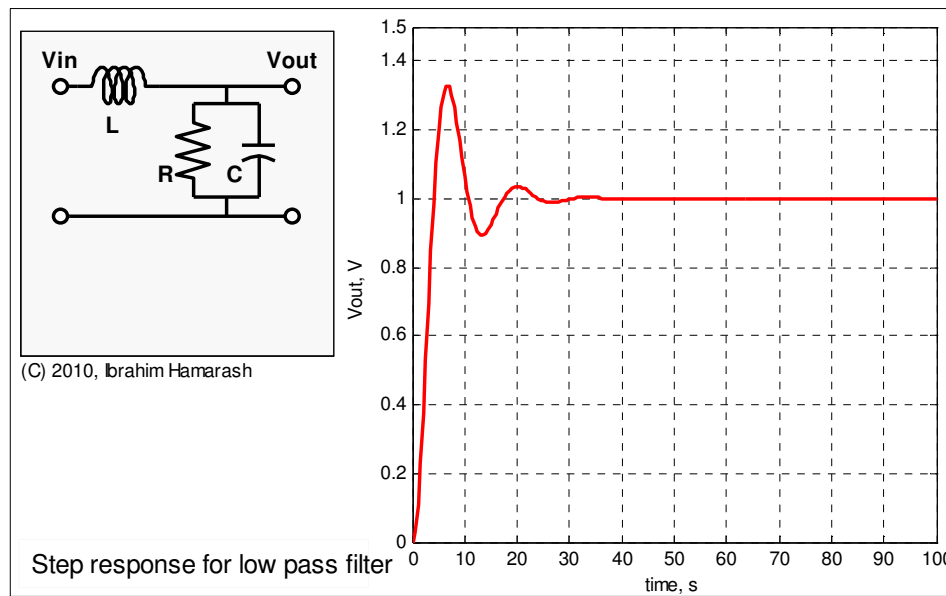

Q2.(40 M.) A dynamic system is represented by the following block diagram. Select a suitable method to find its stability. **Hint:** finding the transfer function will help.

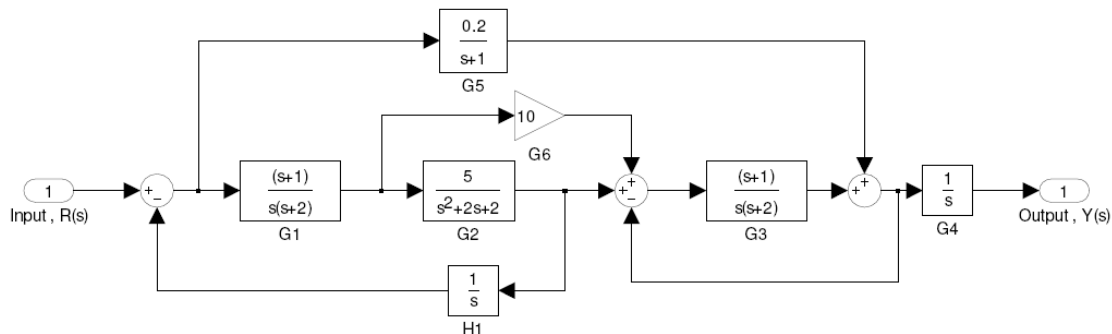

Q3.(20 M.) A mathematical model for a system is given by the following fourth order differential equation:

$$3 \frac{d^4 y(t)}{dt^4} + 4 \frac{d^3 y(t)}{dt^3} + 2 \frac{d^2 y(t)}{dt^2} + \frac{dy(t)}{dt} + y(t) = 0.5 r(t)$$

Where $y(t)$ and $r(t)$ are the output and the input respectively. Answer the following questions:

1. Convert the model into Transfer Function form
2. Check the stability of the system